

| REV | Description  | DATE       | BY |
|-----|--|------------|----|
| A3  | Production release.  | 10/21/2011 | GC |
| A3A | Updated in conjunction with the release of the SRM. Typos and naming changes. No change in design. | 11/5/2011  | GC |
|     |  |            |    |
|     |  |            |    |

| PAGE NO. | SCHEMATIC PAGE                |
|----------|-------------------------------|
| 1        | COVER PAGE                    |
| 2        | POWER MANAGEMENT              |
| 3        | PROCESSOR 1 OF 3              |
| 4        | PROCESSOR 2 OF 3              |
| 5        | PROCESSOR 3 OF 3              |
| 6        | LED, CONFIGURATION AND BUTTON |
| 7        | MEMORY                        |
| 8        | ETHERNET AND USB HOST         |
| 9        | USB CONCENTRATOR              |
| 10       | SERIAL AND JTAG               |
| 11       | EXP CONN, uSD, AND LDO        |

This schematic is **\*NOT SUPPORTED\*** and DOES NOT constitute a reference design. Only "community" support is allowed via resources at [BeagleBoard.org/discuss](http://BeagleBoard.org/discuss).

THERE IS NO WARRANTY FOR THIS DESIGN , TO THE EXTENT PERMITTED BY APPLICABLE LAW. EXCEPT WHEN OTHERWISE STATED IN WRITING THE COPYRIGHT HOLDERS AND/OR OTHER PARTIES PROVIDE THE DESIGN "AS IS" WITHOUT WARRANTY OF ANY KIND, EITHER EXPRESSED OR IMPLIED, INCLUDING, BUT NOT LIMITED TO, THE IMPLIED WARRANTIES OF MERCHANTABILITY AND FITNESS FOR A PARTICULAR PURPOSE. THE ENTIRE RISK AS TO THE QUALITY AND PERFORMANCE OF THE DESIGN IS WITH YOU. SHOULD THE DESIGN PROVE DEFECTIVE, YOU ASSUME THE COST OF ALL NECESSARY SERVICING, REPAIR OR CORRECTION.



|       |                             |                       |         |
|-------|-----------------------------|-----------------------|---------|
| Title |                             | BeagleBone Cover Page |         |
| Size  | Document Number             | Rev                   |         |
| B     | 450-5500-001                | A3A                   |         |
| Date: | Saturday, November 05, 2011 | Sheet                 | 1 of 11 |

# 5V DC POWER

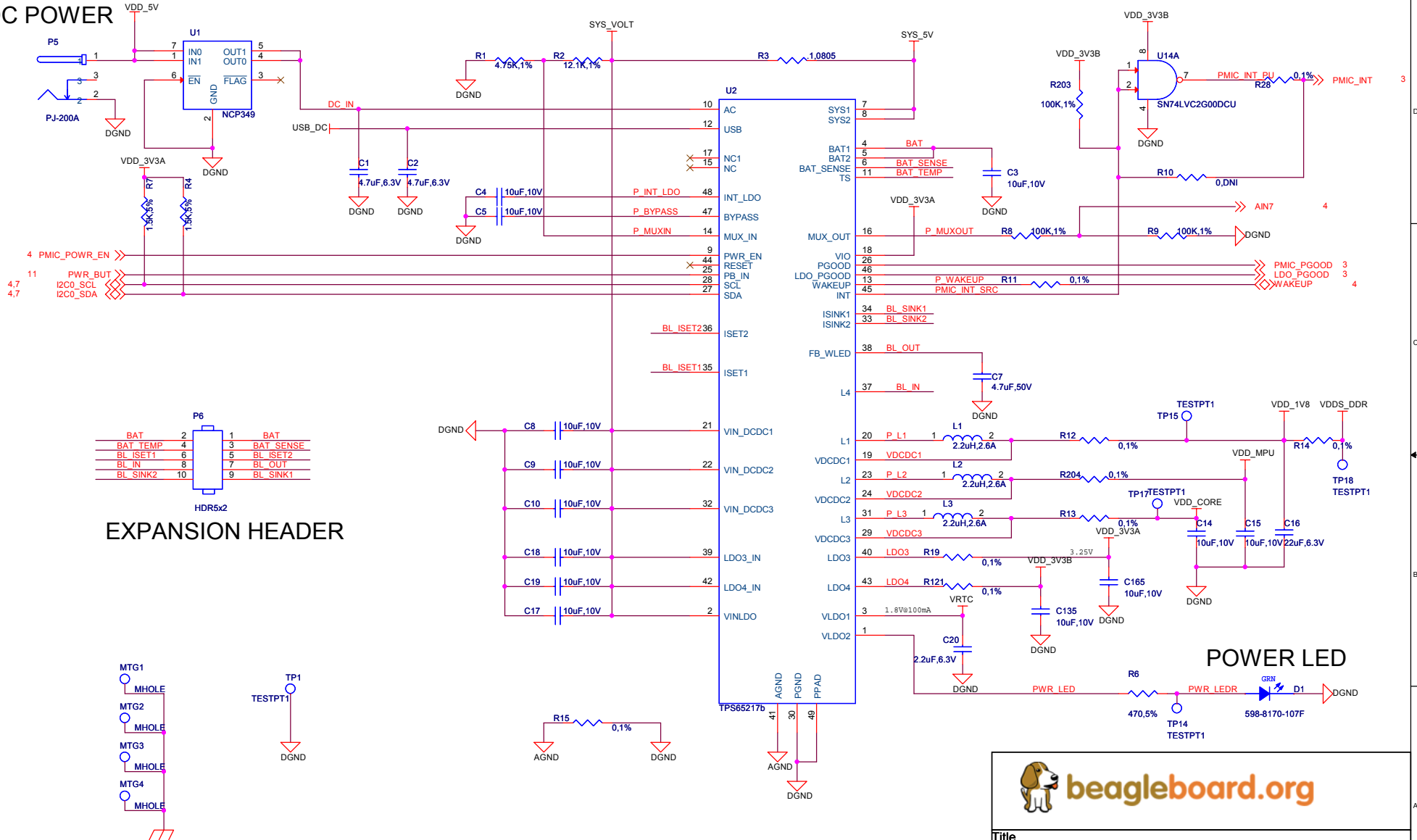

## EXPANSION HEADER

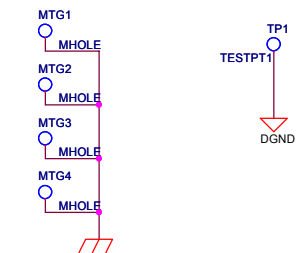
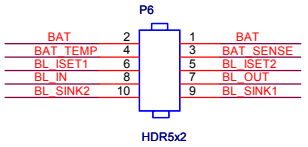

|                                      |                                 |            |
|--------------------------------------|---------------------------------|------------|
| Title<br>BeagleBone Power Management |                                 |            |
| Size<br>B                            | Document Number<br>450-5500-001 | Rev<br>A3A |
| Date:<br>Saturday, November 05, 2011 | Sheet<br>2                      | of<br>11   |

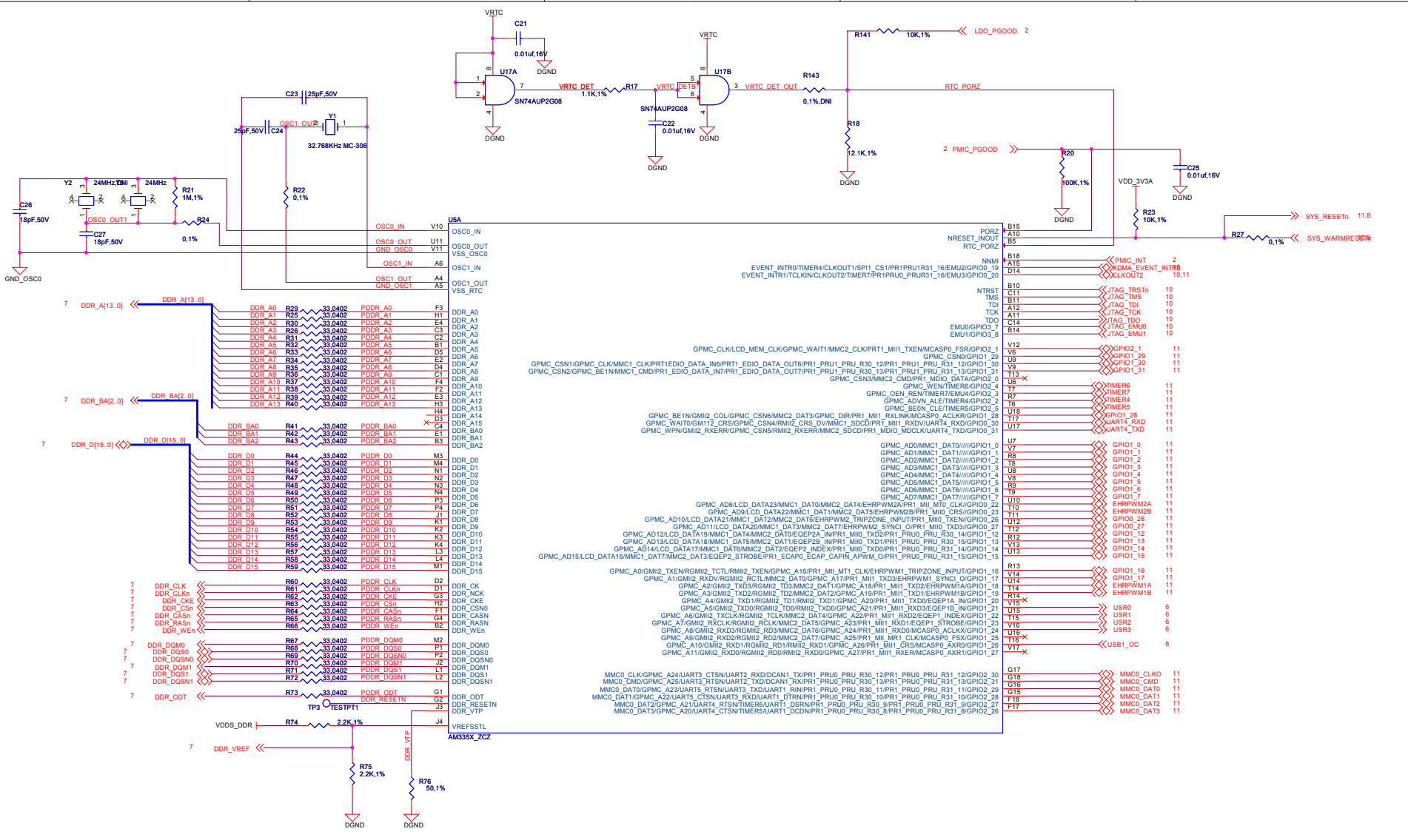

|       |                             |                             |     |       |
|-------|-----------------------------|-----------------------------|-----|-------|
| Title |                             | BeagleBone Processor 1 of 3 | Rev | ASA   |
| Size  |                             | Document Number             |     |       |
| C     | 450-5500-001                |                             |     |       |
| Date: | Saturday, November 05, 2011 | Sheet                       | 3   | of 11 |

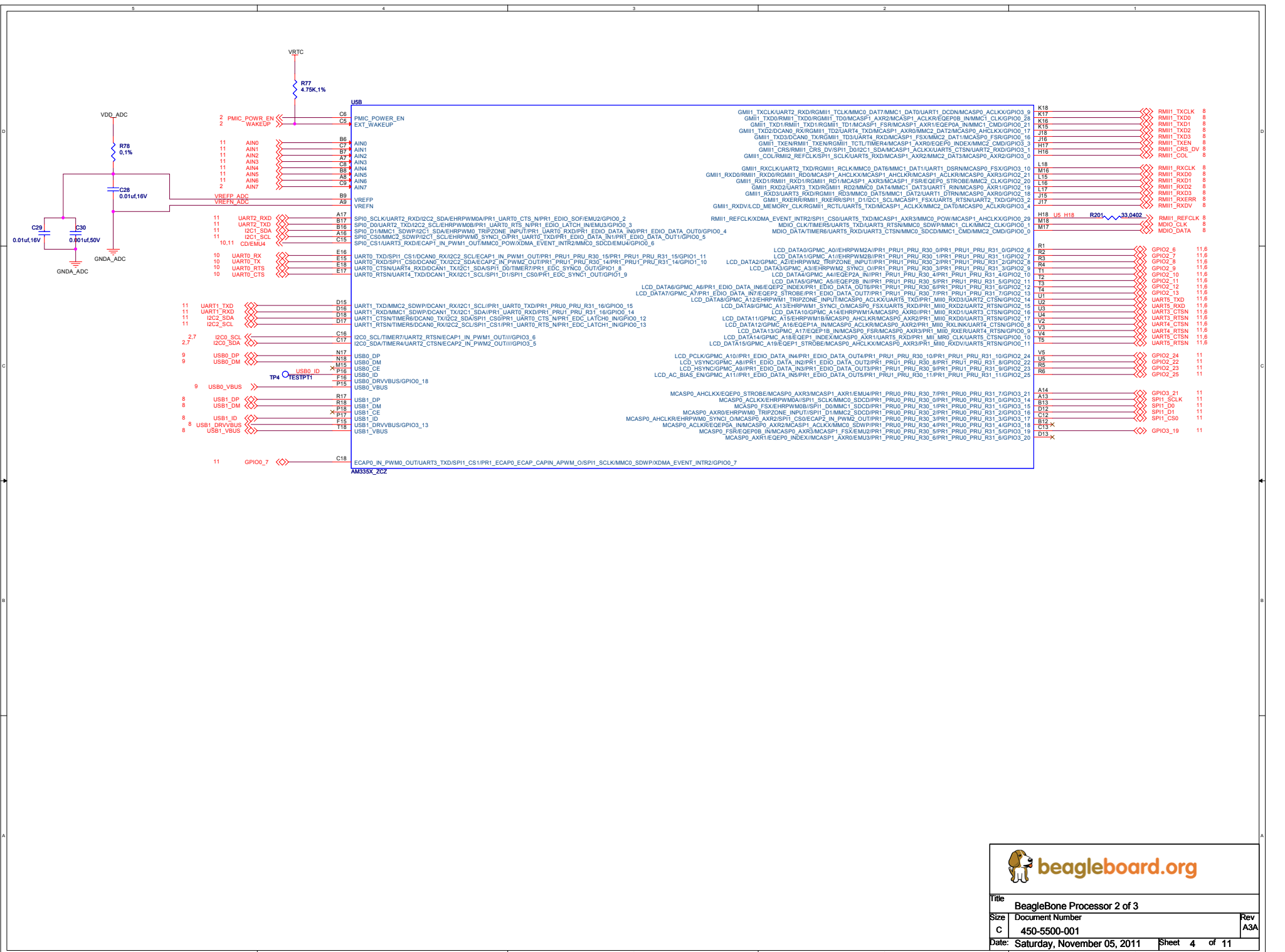

|       |  |  |                             |  |               |
|-------|--|--|-----------------------------|--|---------------|
| Title |  |  | BeagleBone Processor 2 of 3 |  |               |
| Size  |  |  | Document Number             |  |               |
| C     |  |  | 450-5500-001                |  | Rev<br>ASA    |
| Date: |  |  | Saturday, November 05, 2011 |  | Sheet 4 of 11 |



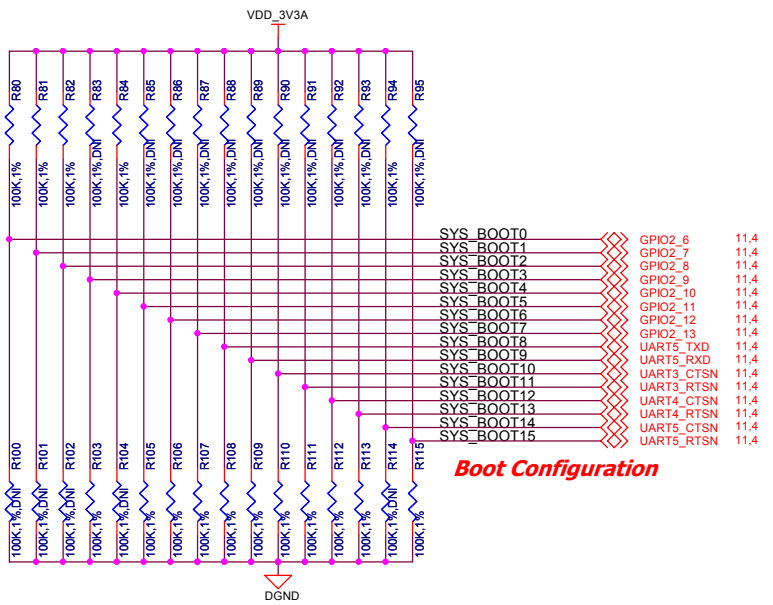

BOOT ORDER....MMC....SPI....UART ....USB.....24MHZ

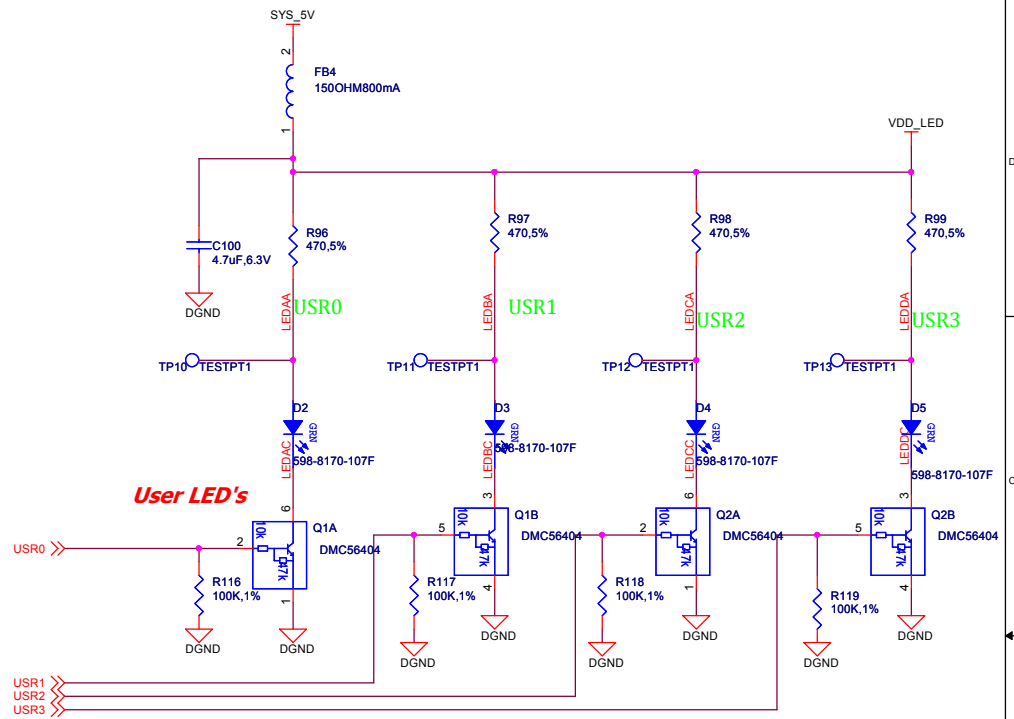

### RESET BUTTON

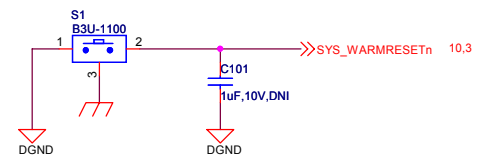

|   |                             |               |
|---|-----------------------------|---------------|
| Title                                   |                             |               |
| BeagleBone LED, Configuration and Reset |                             |               |
| Size                                    | Document Number             | Rev           |
| B                                       | 450-5500-001                | A3A           |
| Date:                                   | Saturday, November 05, 2011 | Sheet 6 of 11 |

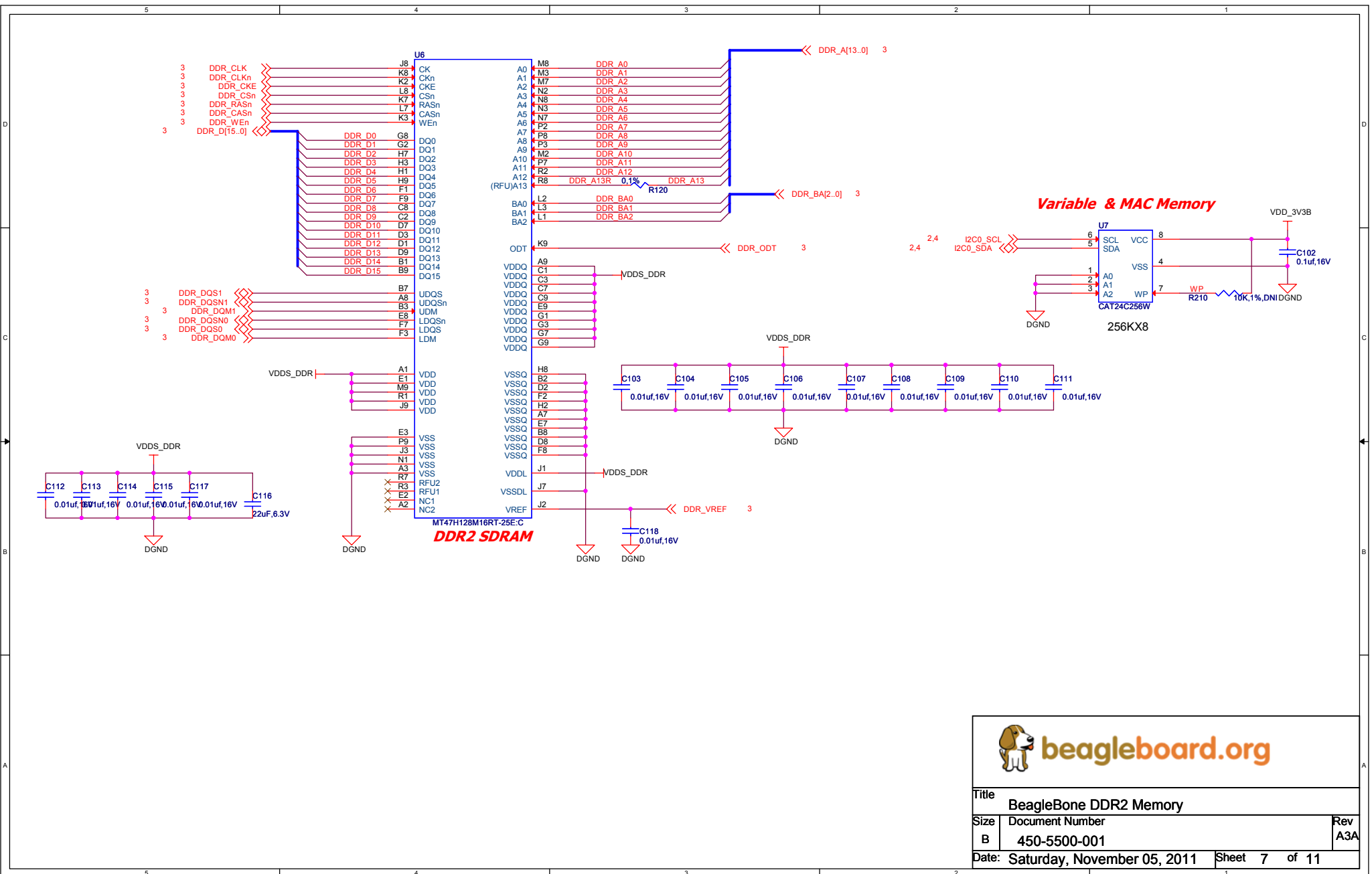

|       |                             |                        |
|-------|-----------------------------|------------------------|
| Title |                             | BeagleBone DDR2 Memory |
| Size  | Document Number             | Rev                    |
| B     | 450-5500-001                | A3A                    |
| Date: | Saturday, November 05, 2011 | Sheet 7 of 11          |

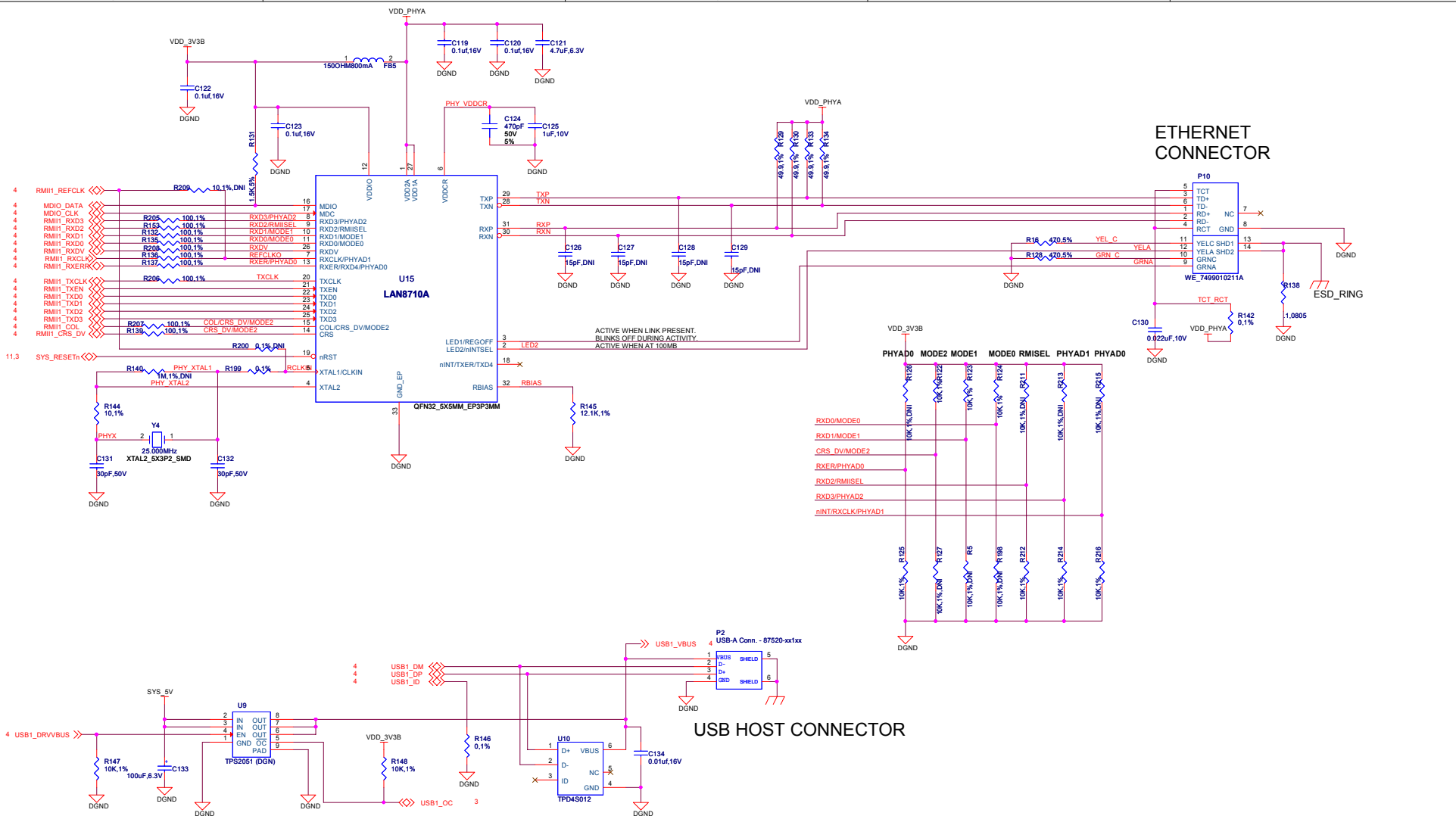

### ETHERNET CONNECTOR

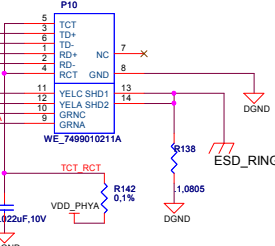

### USB HOST CONNECTOR

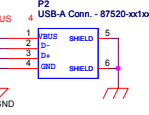



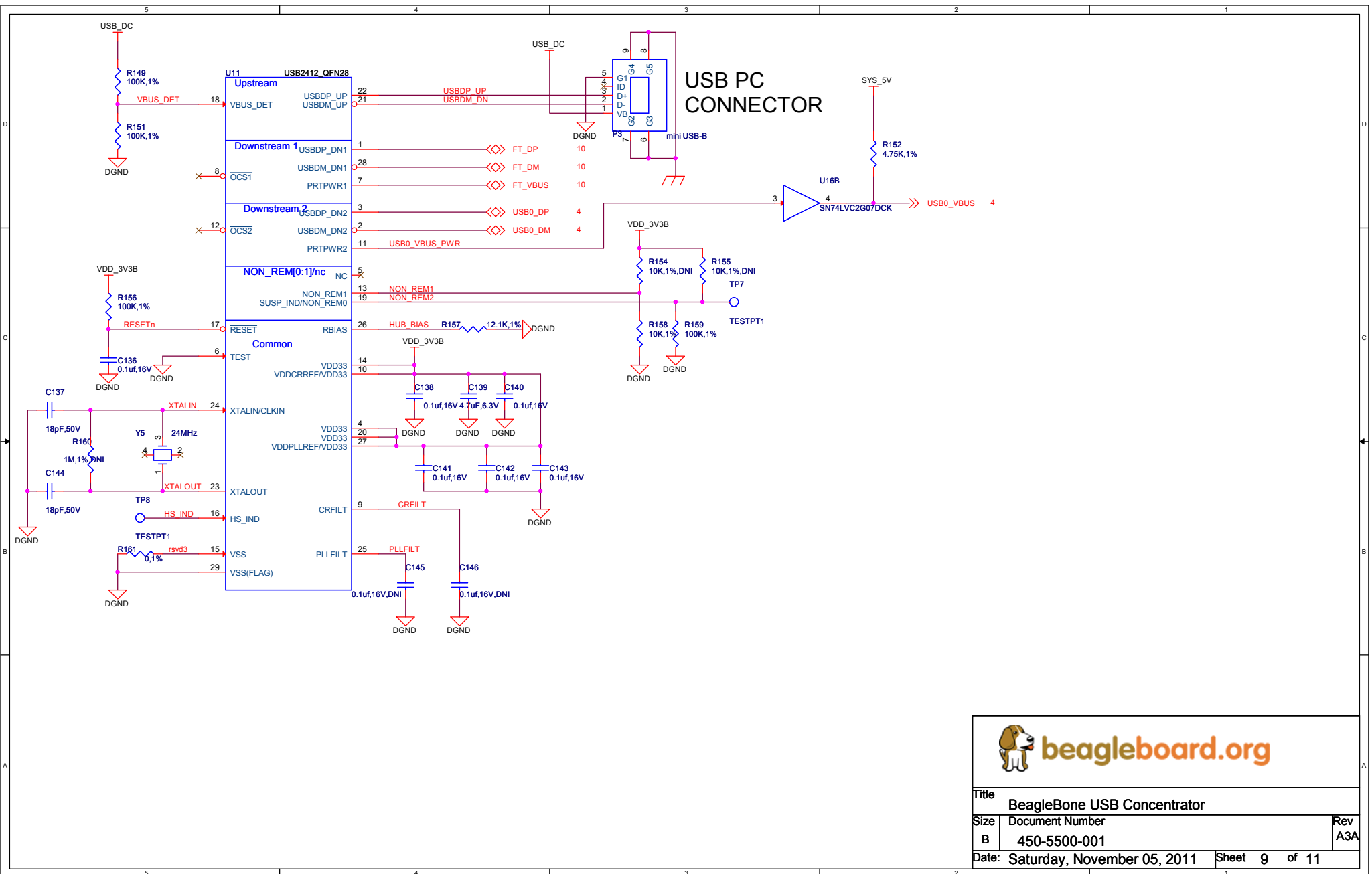

|       |                             |                             |         |
|-------|-----------------------------|-----------------------------|---------|
| Title |                             | BeagleBone USB Concentrator |         |
| Size  | Document Number             | Rev                         |         |
| B     | 450-5500-001                | A3A                         |         |
| Date: | Saturday, November 05, 2011 | Sheet                       | 9 of 11 |

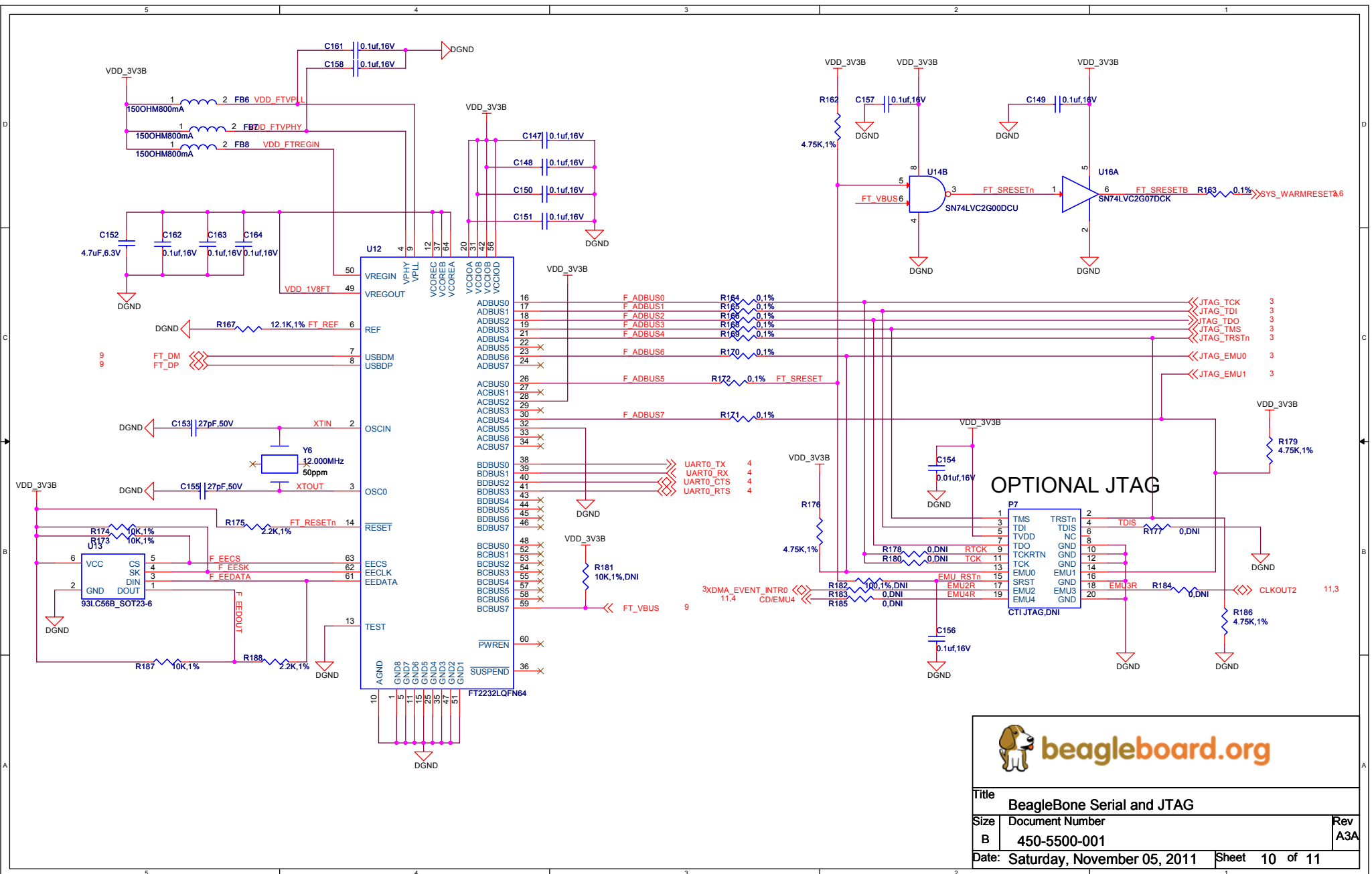

**OPTIONAL JTAG**



|       |                             |                            |          |
|-------|-----------------------------|----------------------------|----------|
| Title |                             | BeagleBone Serial and JTAG |          |
| Size  | Document Number             | Rev                        |          |
| B     | 450-5500-001                | A3A                        |          |
| Date: | Saturday, November 05, 2011 | Sheet                      | 10 of 11 |

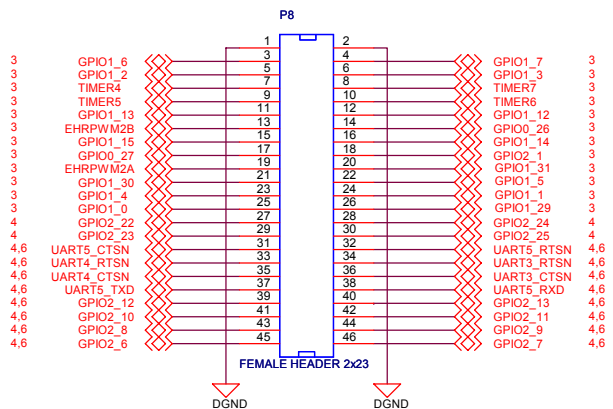

### EXPANSION HEADER

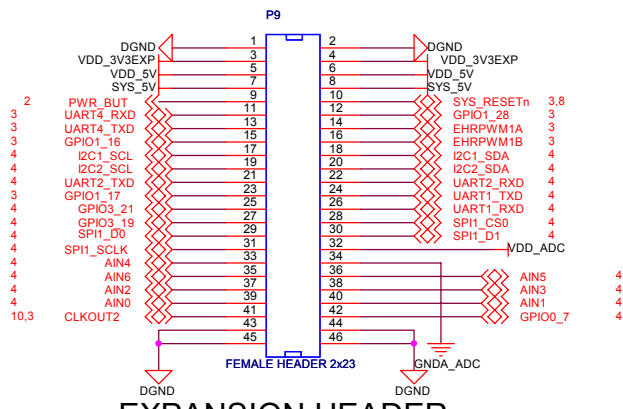

### EXPANSION HEADER

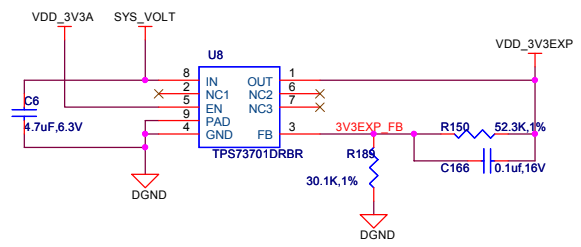
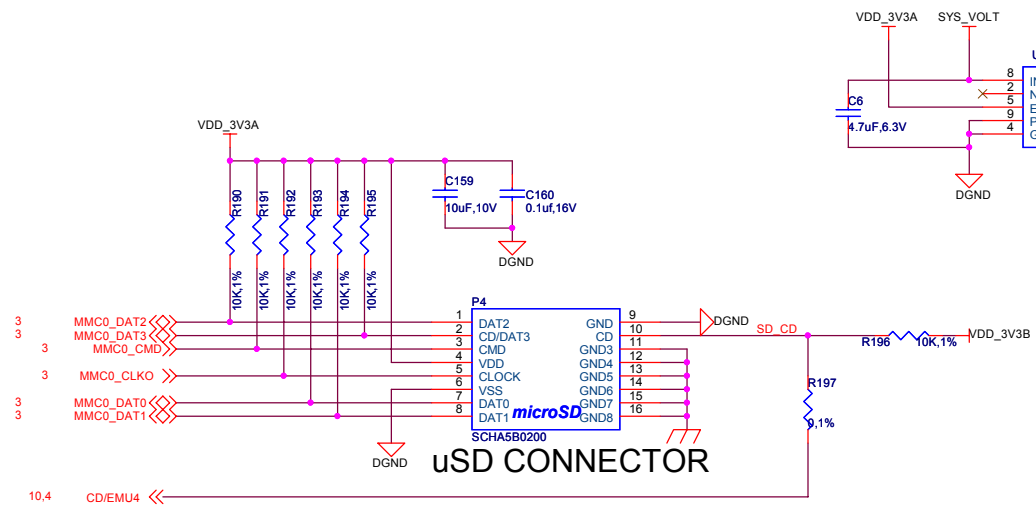

**beagleboard.org**

|  |                             |                |
|--|-----------------------------|----------------|
| Title  |                             |                |
| BeagleBone Expansion Headers, SD/MMC and LDO |                             |                |
| Size   | Document Number             | Rev            |
| B  | 450-5500-001                | A3A            |
| Date:  | Saturday, November 05, 2011 | Sheet 11 of 11 |